

# ECO SENSORS, INC.

12-06

## OZONE ANALYZER Model UV-100

### INSTRUCTIONS FOR USE

#### GENERAL

The model UV-100 is a UV absorption analyzer designed specifically for ozone. It uses a mercury lamp filtered for absorption at 254 nm as is typical of other commercial instruments. The Eco Sensors, Inc., design is very compact and uses the latest digital microprocessor technology. The UV-100 covers three ranges: 0-1, 0-10 and 0-900 ppm. Its outputs are a LCD digital display, 0-2.5 VDC, 4-20 mA, and a time and date stamp digital data stream for external readout and data logging. The data output are via serial port and USB. There is also an internal data logger which can store and forward approximately 4 days of data. The theory of operation is described in Appendix B.



Panel LEDs indicate "on", recalibrate, change input filter, and the ozone concentration at the sampling point exceeds .1 ppm.

The instrument is conditionally warranted for one year. Read the warranty statement at the end of this manual.

#### OPERATION

Plug the AC adapter into AC power and plug the adapter's output plug into the power jack on the instrument. Find the power switch on the rear panel and turn the instrument on. The green LED "on" indicator and the LCD display backlighting should illuminate. **Allow at least 1/2 hour warm-up.** More than 1 hour is preferred if time permits. Initial ppm readings may start out high and possibly drop to zero for a few minutes. Then the readings will tend towards the actual value as the systems settles into equilibrium.

**The compact, high-speed sample pump in the instrument makes a buzzing sound. This is normal.**

Connect your sample feed tubing to the instrument's 1/4" input compression fitting or via a small optional sample line filter. The range is selected automatically by the instrument unless it is set to a preferred range by the Function control on the front panel. See further instructions on Range Selection below.

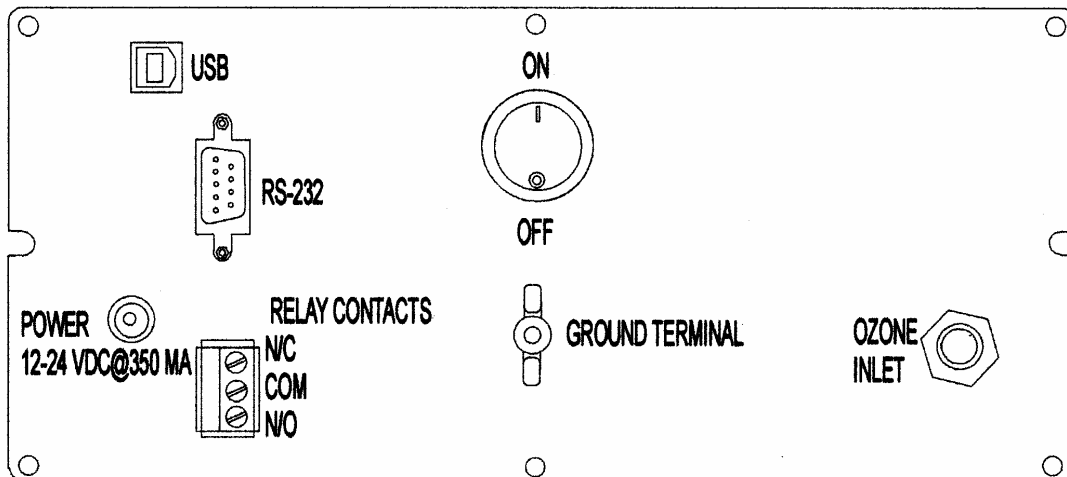
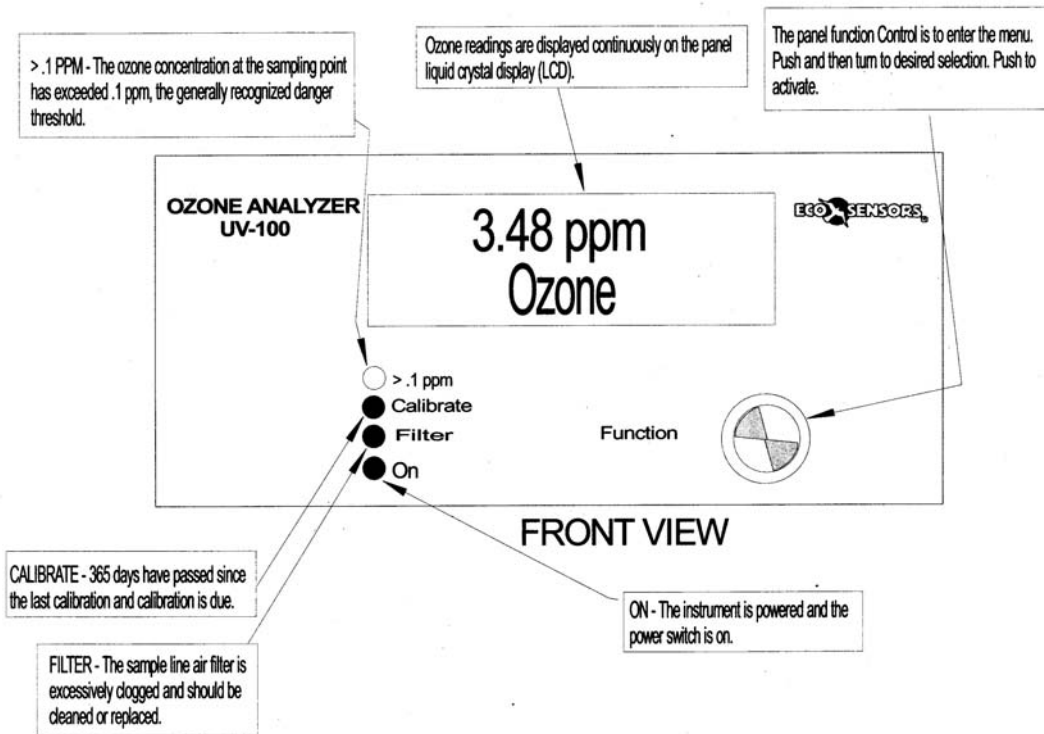

**REAR VIEW**

**Use only the sample air filter supplied with the instrument. Other filters, especially those with a greater pressure drop, can materially affect the readings. This will be noticed if the instrument's zero is significantly above 0 ppm with no ozone present,**

## DATA READOUT

Ozone readings are displayed continuously on the panel liquid crystal display (LCD). The displayed data is updated every 10 seconds. There are also voltage, current loop, and digital outputs on the rear panel described in Outputs to External Equipment below.

## FUNCTION CONTROL

The panel Function Control is to access the internal microprocessor. The knob is gently but firmly pushed in, held there until a response is seen in the LCD display, released, turned to select a function, and then pressed momentarily to activate the selected function.

After the UV-100 has warmed up, press the Function Control in for a few seconds. MENU will appear on the LCD. Release the Function Control after MENU appears. Then SCL DAT CFG <- will appear.

- SCL = Scaling Factor used for manual range settings of analog output. (The value chosen here will determine the resolution of your analog output)
  - 0 – 1ppm is the max range (2.5V or 20mA)
  - 0 – 10ppm is the max range (2.5V or 20mA)
  - 0 – 100ppm is the max range (2.5V or 20mA) unless 0-900 ppm is specified.

\*This does NOT affect the digital output in any way, only the voltage or current output.
- DAT = Data logger control. The default setting is for the instrument to send a continuous stream of data through its serial and USB ports. Pushing on DAT will give the following options:
  - XMT = To end the logging operation discussed below and transmit the stored data.
  - LOG = Sends data continuously as well as storing it internally as a continuous logging function. The data will be updated every ten seconds and the internal logger will store up to approximately 4 days of data.
  - END = Stop storing (logging) data.
  - Push <- to return to main menu.
- CFG = Change of certain parameters. Clicking it will open up the options:
  - CAL = For factory technician use only
  - REL = To enter set-point data for relay. Enter ON data as ON = XXX.XXX (ppm) and OFF data as OFF = YYY.YYY (ppm).
  - D/T = Change internal clock date and time. Locate cursor on the time or date and rotate to change. Push once to move to the next date or time. Push once again to effect the change. The display will blink indicating that the change has been accepted. Push again to get back to the main menu.

To exit all menus push <- on each menu until the LCD displays MEASURING OZONE.

## CALIBRATION

The Eco Sensors, Inc., UV-100 is calibrated to a reference instrument whose calibration is traceable to the US government standards agency, NIST. The UV-100 has internal sensors and programming to correct its calibration for temperature and pressure.

When the UV-100 is calibrated an internal clock is started. After 365 days have passed, the panel indicator LED "calibrate" will light, indicating that the recommended annual calibration is due.

Calibration data and date for your UV-100 are included in the document package included with the instrument.

Recalibration can be done simply and quickly at Eco Sensors, Inc. or one of its authorized service centers.

**IMPORTANT NOTE:** The calibration of the UV-100 is pressure (P) and temperature (T) compensated. Many other UV analyzers on the market are not P and T compensated even though their calibration is certified as traceable to an international standard. The major difference that will be observed from the lack of P and T compensation is at high altitudes the UV-100 will read a higher ozone concentration inversely proportional to the barometric pressure at the higher altitude versus the barometric pressure at sea level.

A convenient formula for approximating the correction is:

For every 1,000 meters of altitude, add 14% to the uncorrected reading.  
For every 1,000 feet of altitude, add 5% to the uncorrected reading.

## PANEL LED INDICATORS

Illumination of the LEDs mean:

**ON** - The instrument is powered and the power switch is on.

**FILTER** - The sample line air filter is excessively clogged and should be cleaned or replaced.

**CALIBRATE** - 365 days have passed since the last calibration and a recalibration is due.

**> .1 PPM** - The ozone concentration at the sampling point has exceeded .1 ppm, the generally recognized danger threshold.

## TRANSMITTING DATA TO THE PC

Data from the UV-100 is easily transmitted to the PC using the Microsoft Windows® operating system. The program used for this is HyperTerminal found in Windows. To set up your PC to receive and display UV-100 data, see the procedure shown in Appendix A.

The data output will look like this:

## UV-100 SERIAL OUTPUT FORMAT

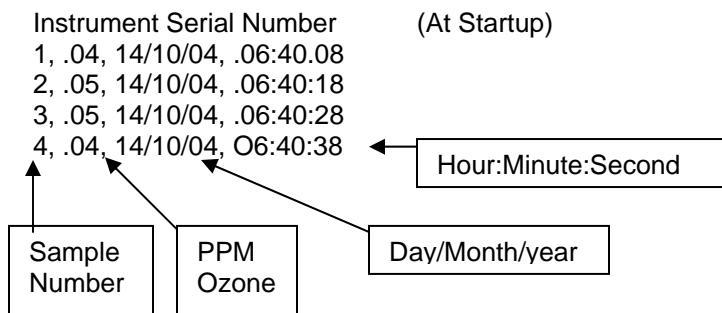

## OUTPUTS TO EXTERNAL EQUIPMENT

**0-2.5 volts DC** - ( $X V = \text{full ppm scale}$ ) Pins 1 and 5 of the RS-232 connector.

**4-20 mA** - (4 mA = 0 ppm, 20 mA = full scale) Pins 9 and 5 of the RS-232 connector

**Digital output with time and date information** - ASCII via RS-232 serial connector and via the USB connector. THIS INSTRUMENT USES AN EXTERNAL SERIAL PORT TO USB ADAPTER. When you unpack the USB adapter box, be sure to find the CD disc that has the driver for your computer.



**Set Point Relay Contacts** These have their own output plug and socket connector on the rear of the instrument. There are three terminals to select Normally Open (NO) contacts and Normally Closed contacts (NC). The relay setpoint is described under FUNCTION CONTROL above.

## SERVICE AND MAINTENANCE

There are no user serviceable parts in this instrument. Opening the enclosure will void the warranty.

**FILTER** The input airline filter is an option. If your instrument has one, the external filter cartridge can be opened by a half turn and firm pulling apart. The cone-shaped filter inside can be gently washed and dried. The filter has 30 micron pores. Replacement filter cartridge and filter elements can be ordered through your distributor.

## AC ADAPTER

For use in North America and other areas with 120 V 60 HZ, the Eco Sensors P-20 adapter should be used. For other areas adapters should be purchased locally that fit local wall sockets and conform to local codes. The output should be 12 volts DC unregulated, 500 mA. The plug to our instrument should fit a 5.5/2.5 mm socket with the center pin +. For further details see our Tech Note P-102.

## SPECIFICATIONS

*Sensor:* Narrow band filter to UV detector at 254 nm.

*Sensitivity:* First responds at approximately .01 ppm

*Accuracy:* 0-100 ppm, 2 %.      100-900 ppm 5%  
*Response time:* Within one minute of when gas reaches the sensor  
*Temperature and humidity range:* 10-40 deg C and 0-80% relative humidity.  
*Fuse:* Self-resetting. Not user replaceable.  
*Filter (sample inlet):* 30 micron.  
*Supply voltage required:* 12-24 volts DC, 400 mA.  
*Size of instrument (HXWXD):* 95 X 210 X 216 mm (3 3/4" X 8 1/4" X 8 1/2").  
*Weight of instrument:* 2.1 kg (4.7 lbs.).  
*Fuse:* Internal self-resetting.

## PRECAUTIONS

It is recommended to ground the instrument to earth ground via the ground lug in the center of the back panel. This will give more immunity to noise and various external electrical influences such as may be encountered if operating near heavy machinery, high voltage, neon lamps, etc.

- Allow at least 30 minutes warm-up.
- Read all instructions in this manual.
- Keep instrument dry. Never let water or other liquids into the sensor.
- Do not drop the instrument or subject it to continuous vibration.
- Do not store in high levels of dust.
- Do not clean the instrument with cleaning chemicals or solvents. Clean it with a damp cloth.
- Do not operate near heavy aerosols (spray) usage or where oxygen is being administered.
- Call a qualified electrician if you have any doubts about voltages, currents, electrical practice, etc.
- While not necessary for typical uses, for highest precision results in electrically noisy locations, the instrument should be grounded to earth to achieve maximum stability.

## WARRANTY

This product is warranted against defects in materials and workmanship for one year following the date of purchase by the original owner. This warranty does not include damage to the product as a result of misuse, accident, damage, modifications or alterations, and it does not apply if the instructions in this manual are not followed.

If a defect develops during the warranty period, Eco Sensors at its election will repair the instrument or replace it with a new or reconditioned model of equivalent quality. In the event of replacement with a new or reconditioned instrument, the replacement unit will continue the warranty of the original unit.

To return the instrument contact your distributor, or call Eco Sensors at (800) 472-6626 or e-mail at [sales@ecosensors.com](mailto:sales@ecosensors.com) to receive return instructions and a Return Material Authorization (RMA) number.

Except as provided herein, Eco Sensors makes no warranties, express or implied, including warranties of merchantability and fitness for a particular purpose. Eco Sensors shall not be liable for loss of use of this instrument or other incidental or consequential damages, expenses or economic loss, or claims for such damage or economic loss.

RECORD YOUR SERIAL NUMBER HERE \_\_\_\_\_

KEEP THIS MANUAL AND WARRANTY FOR YOUR RECORDS.

Eco Sensors is a registered trademark of Eco Sensors, Inc.

© Eco Sensors, Inc. 2004. Revision 12/06

For brochures, application and tech notes, and other useful information, visit our extensive website at [www.ecosensors.com](http://www.ecosensors.com). E-mail us at [sales@ecosensors.com](mailto:sales@ecosensors.com).

## APPENDIX A

### SETTING UP YOUR PC FOR RS-232 (SERIAL PORT) DATA ENTRY AND DISPLAY

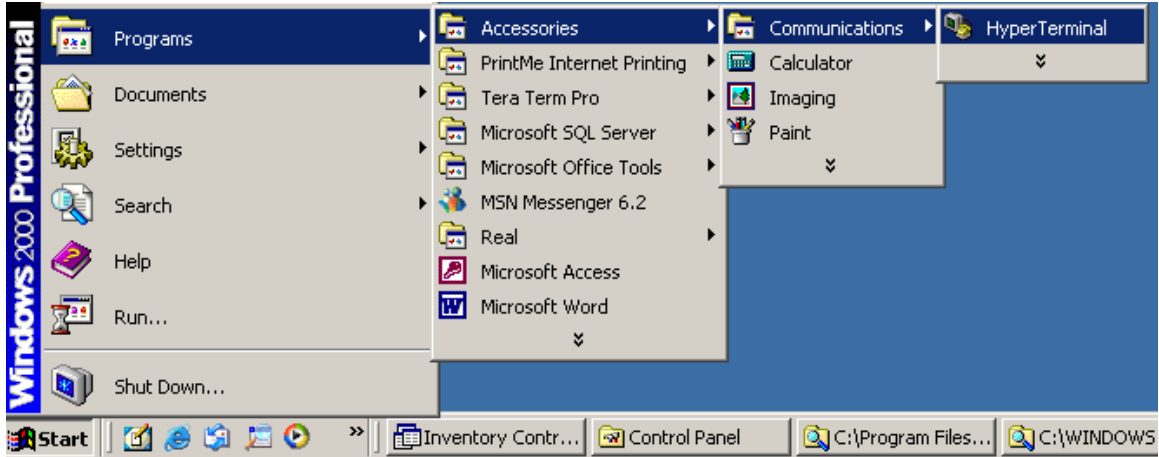

1 - Go to **HYPERTERMINAL** from the **ACCESSORIES** folder of the **PROGRAMS** directory. Click on **HYPERTERMINAL**.

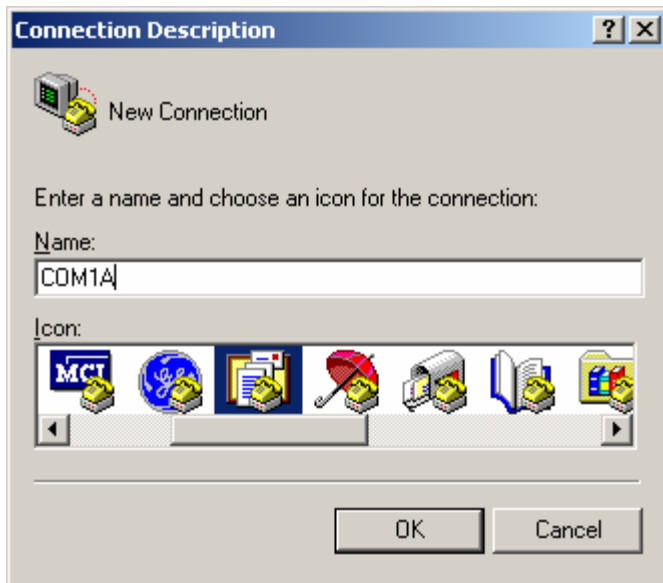

2 - You will be asked for a CONNECTION DESCRIPTION. We used COM1A here because we are using the COM 1 port to input the data. Click OK.



3 - Choose which port you will use to connect to the computer. Here we have selected COM 1. Click OK.

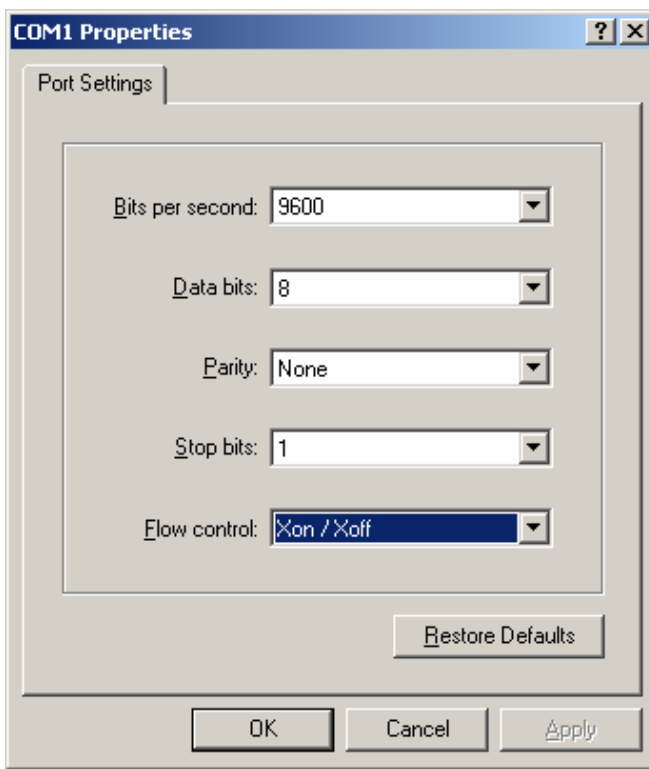

4 - Enter your PORT SETTINGS as above: Bits per second - 9600, Data bits - 8, Parity - None, Stop bits - 1, Flow control - XON/XOF. Click OK. You're done!

## APPENDIX B

### THEORY OF OPERATION

The Eco Sensors Ozone Monitor is designed to enable accurate measurements of indoor ozone over a wide dynamic range extending from a limit of detection of .01 ppm by volume (ppmv) to an upper limit of about 1,000 ppm based on the well established technique of absorption of ultraviolet light at 254 nm. The Ozone Monitor is light weight (4.7 lb., 2.1 kg.) and has a low power consumption (~5 watt) relative to conventional instruments and is therefore well suited for applications such as:

- Industrial hygiene monitoring where ozone may be present in the workplace.
- Control of ozone generators and systems.
- Research and quality checking of ozone emitting equipment.
- Monitoring high ozone concentrations such as process off-gassing.

#### Theory of Operation

Absorption of UV light has long been used for measurements of atmospheric ozone with high precision and accuracy. The ozone molecule has an absorption maximum at 254 nm, coincident with the principal emission wavelength of a low-pressure mercury lamp. Fortunately, few molecules found at significant concentrations in the atmosphere absorb at this wavelength. However, interferences, such as organic compounds containing aromatic rings, can occur in highly polluted air.

Figure 1 is a schematic diagram of the ozone monitor. Ozone is measured based on the attenuation of light passing through a 6.2 cm long absorption cell fitted with quartz windows. A low-pressure mercury lamp is located on one side of the absorption cell, and a photodiode is located on the opposite side of the absorption cell. The photodiode has a built-in interference filter centered on 254 nm, the principal wavelength of light emitted by the mercury lamp. An air pump draws sample air into the instrument at a flow rate of approximately 1 L/min. A solenoid valve switches so as to alternately send this air directly into the absorption cell or through an ozone scrubber and then into the absorption cell. The intensity of light at the photodiode is measured in air that has passed through the ozone scrubber ( $I_o$ ) and air that has not passed through the scrubber ( $I$ ). Ozone concentration is calculated from the measurements of  $I_o$  and  $I$  according to the Beer-Lambert Law:

$$C_{O_3} = \frac{1}{\sigma l} \ln\left(\frac{I_o}{I}\right)$$

where  $l$  is the path length (6.2 cm) and  $\sigma$  is the absorption cross section for ozone at 254 nm ( $1.15 \times 10^{-17} \text{ cm}^2 \text{ molecule}^{-1}$  or  $308 \text{ atm}^{-1} \text{ cm}^{-1}$ ), which is known with an accuracy of approximately 1%. The Eco Sensors instrument uses the same absorption cross section (extinction coefficient) as used in other commercial instruments.

The logarithm of equation 1 is approximated in the microprocessor of the instrument with sufficient accuracy to provide five orders of dynamic range; ozone mixing ratios are measured up to 1,000 ppmv, as compared to 1 ppmv for most commercial ozone instruments.

The pressure and temperature within the absorption cell are measured so that the ozone concentration can be expressed as a mixing ratio in parts-per-million by volume (ppmv).

In principle, the measurement of ozone by UV absorption requires no external calibration; it is an absolute method. However, non-linearity of the photodiode response and electronics can result in a small measurement error. Therefore, each instrument is compared with a NIST-traceable standard ozone spectrophotometer in the laboratory over a wide range of ozone mixing ratios. These results are used to calibrate the Ozone Monitor with respect to an offset and slope (gain or sensitivity). Calibration data is supplied with the instrument. It is recommended that the instrument be recalibrated at least once every year and preferably more frequently. The offset may drift due to temperature change or chemical contamination of the absorption cell. An accurate offset correction can be measured from time to time using the ozone scrubber ("zero ozone filter") available for use with the instrument.

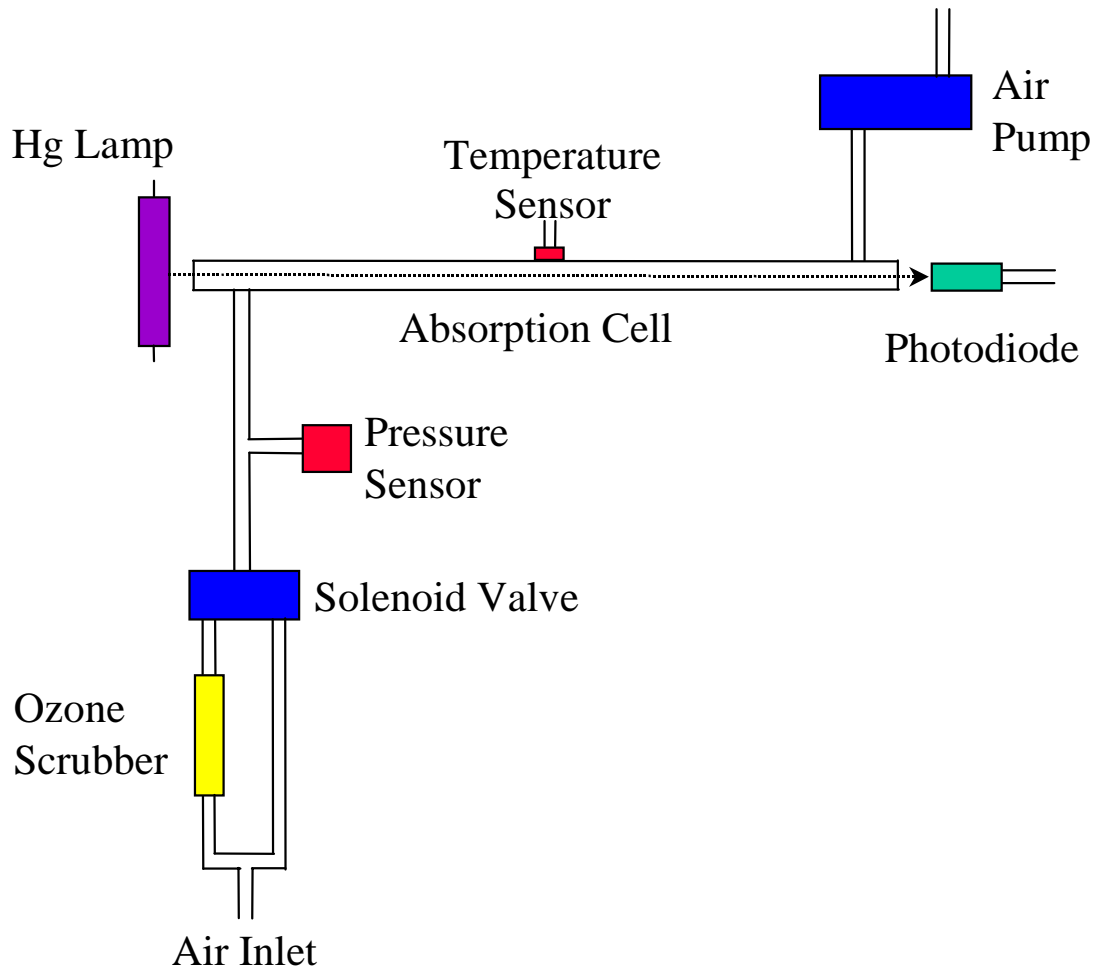

**Figure 1**

**Basic UV Instrument System**